

SPINDLE CONVEYOR THE “UPSIDE-DOWN” CIRCULAR CONVEYOR

VARIABLE SOLUTION FOR DIFFERENT PAINT SHOPS.

Variable spindle conveyor system

The Eisenmann spindle conveyor system is extremely variable and thus has versatile uses. The structure with a special lug with guide rollers and a system spindle head enables the use of various spindle holders: short spindles for oven areas, longer turning spindles with rotary hangers in the painting area.

However, the system is extremely resistant to dirt, moisture and temperatures of up to 250° C. The Eisenmann spindle conveyor is mainly used in plastic paint shops and for painting wheels. In extensive, complex (wheel) paint shops, the various conveyor circles are linked using transmission robots. The varying demands of the painting and drying cycle are thus met in full.

Versions with ascending and descending slopes are possible – for example for energy-saving paint ovens with A lock. These are fitted with several drives when there is correspondingly high pressure on the chain. Automatic lubricating devices are available to reduce the chain tension. Automatic tensioning stations, loaded with springs or weights, ensure an exact pre-tensioning of the conveyor chain.

High process reliability and minimized maintenance work

Tried-and-tested standard components are used for the spindle conveyor system. At the same time, many identical components are used. This ensures high process reliability as well as minimized efforts in maintenance and spare parts stock.

Installation and control concept

Thanks to the mechanically simple structure, the control technology can be made simple: multiple drives are synchronized using modern frequency converter technology, the speed can be continuously adjusted.

Electronic systems, such as bar codes or transponders, are available for the spindles to identify the workpiece carriers.

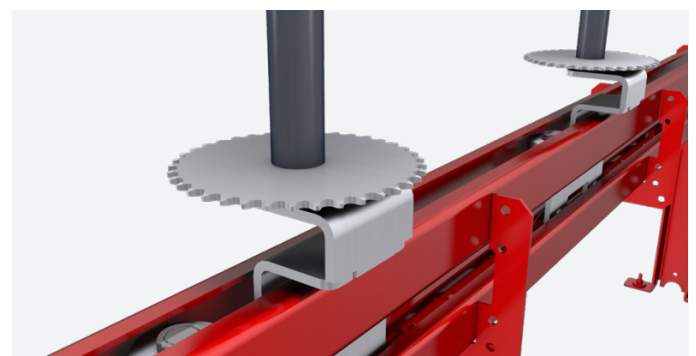

Turning spindle for labyrinth seal.

SPINDLE CONVEYOR THE “UPSIDE-DOWN” CIRCULAR CONVEYOR

Advantages at a glance

- Space-saving and compact design
- Several chain pitches possible for an optimum number of spindles
- Design of the spindle heads with special labyrinth seals (painting cycle) to protect against dirt accumulation on the transport chain also possible
- Energy-saving solutions, for example by means of separate oven conveyors
- Simple control concept with the possibility of integrating further intelligent material flow systems
- High process reliability and low maintenance required due to standardized components adapted to the requirements
- Low-cost, economical overall solutions with respect to investment and operating costs

Technical data

Chain/spindle pitch	600/700 mm
Load capacity	Max. 50 kg/spindle
Speed	Approx. 0,5 - 12 m/min.



Implementation on turning spindles in the painting area.

EISENMANN

www.eisenmann.com

Eisenmann GmbH, Tübinger Str. 81, 71032 Böblingen, Germany, Phone: +49 7031 78-0, Fax: +49 7031 78-1000

2021 © Eisenmann GmbH | 05-2021

All rights reserved. All text, images, photos and graphics are subject to copyright and other intellectual property laws. Content may only be used with the express permission of Eisenmann GmbH. All content, including, without limitation, specifications, descriptions and illustrations, are subject to error and change, in particular with regard to ongoing development of our products in line with technological progress. Changes to content will not be proactively communicated. Technical specifications may vary from country to country.